

NOTES:

1. RED & GREEN ARE CUT OFF ON BOTH ENDS ON THE C332 CABLE.
2. WHITE, ORANGE, BROWN & OUTER BARE ARE CUT OFF INSIDE THE JUNCTION BOX ON THE C334 CABLE.
3. BLUE & BLACK SHIELDED PAIR & VIOLET WIRES ARE CUT OFF ON BOTH ENDS ON THE C334 CABLE.

THIRD ANGLE PROJECTION		REVISIONS				
		REV	DESCRIPTION	ECO NO.	DATE	CHG/CHK
		01	RELEASE TO PRODUCTION.	14445	05/25/17	MIR/CDS

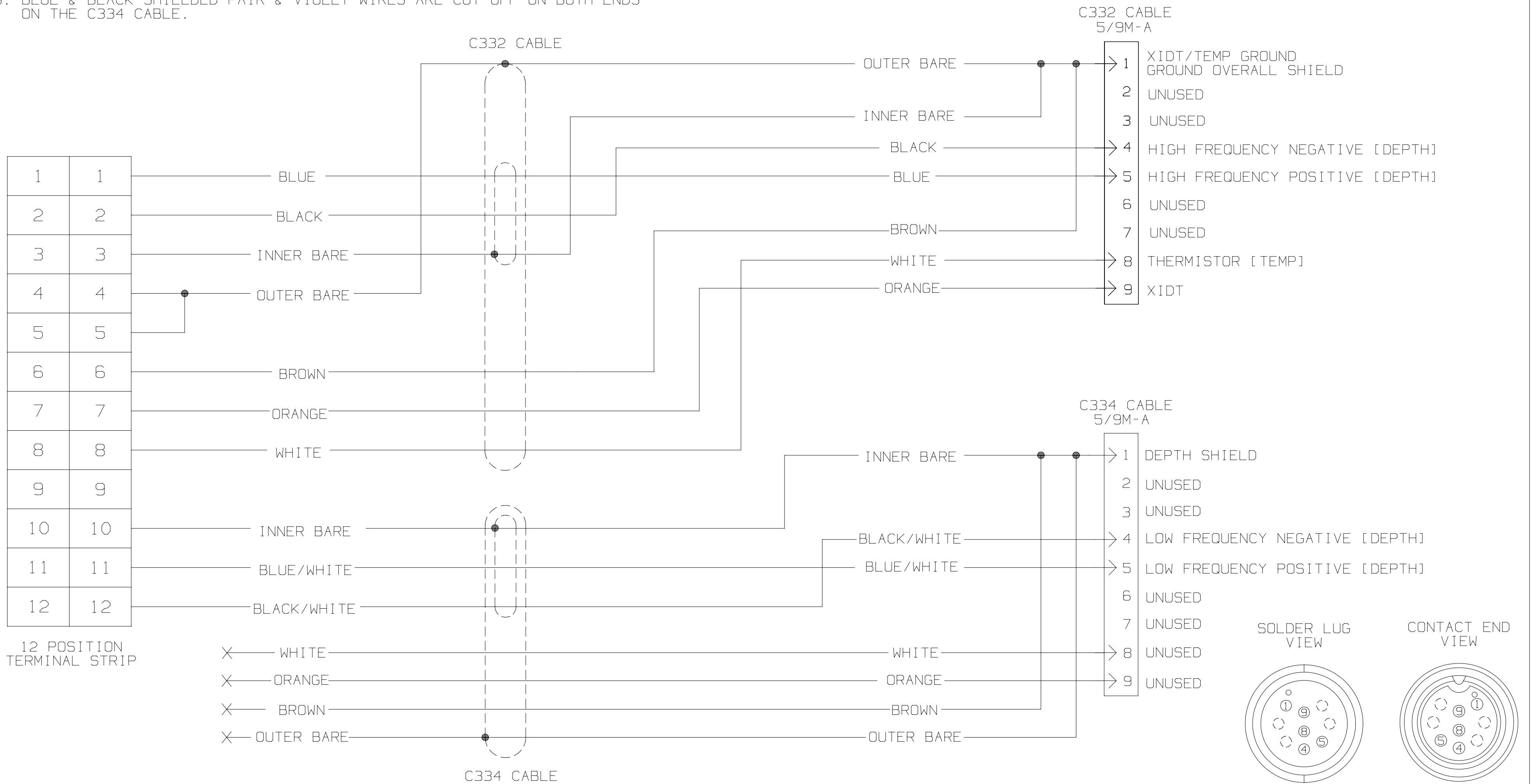

12 POSITION TERMINAL STRIP

UNLESS OTHERWISE SPECIFIED	SIGNATURE	DATE
DIMENSIONS ARE IN INCHES TOLERANCES ON 2 PL DECIMALS ±0.02 3 PL DECIMALS ±0.005 ANGLES ± 1/2° FRACTIONS ± 1/16 SURFACE FINISH	ORIGINATOR	I.ROBB 12/20/16
	DRAWN	I.ROBB 12/20/16
	CHECKED	A.BIATHROW 05/11/17
	APPROVED	W.LETENDRE 05/11/17
MATERIAL	AIRMAR CABLE: 06-332 AND 06-334 CONNECTOR: 05-272-11	

AIRMAR AIRMAR TECHNOLOGY CORPORATION
 35 MEADOWBROOK DR
 MILFORD NH 03055-4613 USA
 TEL: 603-673-9570 FAX: 603-673-4624

TITLE: WIRING, DUAL BAND, SPLICE JUNCTION BOX C332 5/9M-A & C334 5/9M-A NAVICO

SIZE: C SCALE: FULL NUMBER: 91-1349 REV 01